

[ **TAKING YOU  
ONE STEP  
HIGHER** ]



## COMPANY PROFILE:

Under the flagship of Eastman Impex Group, Eastman Conveyor solution was established in 2017, Eastman Group have global presence since 1996 and it has been accredited with ISO 9001:2015. Being a professional company, having upgraded infrastructure in manufacturing and accredited by welding process certification like EN1090 and ISO 3834 (from SLV Mannheim, Germany).

Eastman Group is always a preferred source in global and domestic industry.

## MILESTONES:

- » Establishment of Eastman Impex---Year 1996.
- » Establishment of Fabrication & Forging unit--- Year 1997.
- » Accredited with ISO certification in unit no. 1---Year 1999.
- » Accredited with TS 16949 certification from UL, USA---Year 2005.
- » Entered in new venture of casting and die casting---Year 2006.
- » Accredited with EN 18800 & ISO 3834 (Welding Certification from SLV Mannheim, Germany)--- Year 2009.
- » Expansion of Fabrication & Machining area (CNC/VMC) in unit no. 1--- Year 2009.
- » Accredited with EN1090 (from SLV Mannheim, Germany)--- Year 2014.
- » Establishment of Eastman Exports Pvt. Ltd. for production of Scaffolding & Formwork---Year 2014.
- » Establishment of Automatic High Pressure Castings plant named BDJN Castings ---Year 2015.
- » Establishment of New Plant with an area of 36,000 Square meter & In House Hot Dip Galvanizing facility - Year 2018.
- » Establishment of Eastman Conveyor solutions in 2017.
- » New fabrication shop & Conveyrised powder coating plant started in 2019.

## EASTMAN CONVEYORS SOLUTION:

Eastman is manufacturing Conveyor as per ISO standard for machine tool manufacturer of Indian an imported machines. Under this company, we are also manufacturing Chip Conveyors of various types e.g. Hinged Metal Belt Scraper, Magnetic, Customized Material Handling System. Machine tools manufacturers extensively use our Conveyors as OEM for their conventional as well as CNC Machines.

## AREA OF APPLICATION:

Transport of metal chips and small pieces from machine tools. Suitable for long steel shaving, snarl chips, wool chips, dry processing and wet processing.



**Curly Iron Chips**



**Metallic Chips**



**Curly Aluminum Chips**



**Non Metallic Chips**

## FEATURES:

- » Easy and efficient transferring of chips in Bins
- » Overload protection
- » High Quality & heavy duty steel.
- » Three Phase geared heavy motor
- » Easy in Maintenance

## HINGE BELT CONVEYOR:

Hinge-belt chip conveyors, the most common format, offer an effective means of managing heavy chip loads and stringy chips. Chips that fall from the machine tool land on the conveyor belt and are conveyed away from the machine tool's precision surfaces.



## SCRAPPER CONVEYOR:

Scraper-type chip conveyors are most often used for cast iron, bronze or brass machining, which produces smaller chips that can nest together. Chips fall directly to the bottom of the conveyor, and scrapers drag debris to the discharge end of the conveyor.

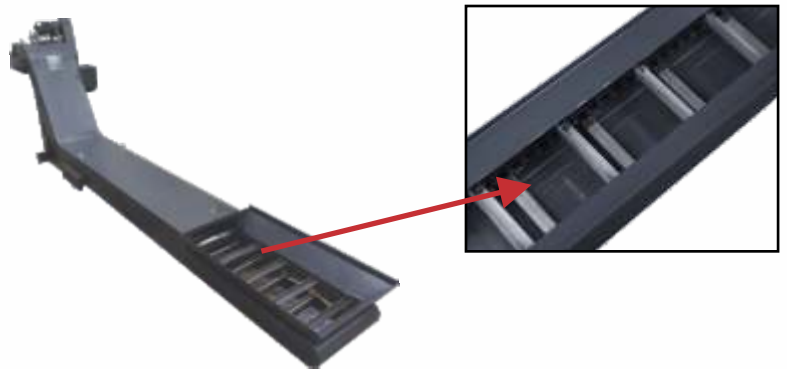

## MAGNETIC CHIP CONVEYOR:

Magnetic chip conveyors are intended for ferrous material applications with small chips. The chips fall onto the conveyor's stainless steel surface and are conveyed by powerful magnets moving underneath. The chips are released from the magnets at the discharge end, and fall freely into a collection container.



## SCREW CONVEYOR:

Screw Conveyor are used in machine where chips need to clean from a narrow space in the machine bed. It is vary as per machine design.

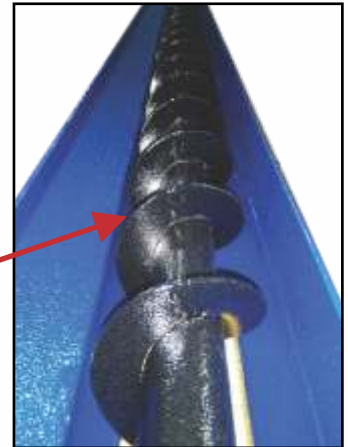

## HEAVY-DUTY COOLANT TANKS:

Coolant storage tanks are made from heavy gauge steel to provide leak-free service in harsh shop environments. Removable cover plates allow easy access to the tank's interior for quick, easy maintenance. Baffles, chip baskets, and removable screens can also be added.



## DRUM TYPE FILTRATION SYSTEM

Drum type filtration system is a combination of scraper conveyor and filter drum that effectively handles small chips arising out of cutting operation such as milling.

The separation of fine metal particles from coolant is effected by the rotating filter drum of finely woven steel mesh. The drum is driven by scraper chain and hence no separate drivers required and also no consumable filter media used.



## MATERIAL MOVEMENT CONVEYOR:

This type of conveyor basically used for material handling as per below type

- Aluminum Profile
- Work Station and benches
- Safety fencing

This is available in spring type chain and belt type also.



## TELESCOPIC COVERS

Telescopic covers are ideal for any machine tool application requiring complete protection of machine ways and ball screws. Telescopic way covers protect against dropped tools, heavy chip loads, cutting oil and coolant.

they can be designed to move along any machine axis.



## BELT CONVEYOR

Rubber conveyor belts are commonly used as components in automated distribution and warehousing.



INCLINED BELT CONVEYOR

## CHIP TROLLEYS/CHIP BINS

Chip collecting trolley is used for collecting the chips conveyed by conveyors. It enables sending the chip out the working area.

Chip collecting trolley has two types:-

- » Dry type Trolley.
- » Wet type Trolley.



## ROLLER CONVEYOR

Roller conveyor are an economical solution for material handling applications such as on loading docks, for baggage handling, or on assembly lines among many others.



## SLAT CONVEYOR

Slat conveyors are a type of conveying technology that utilizes a chain-driven loop of slats to move product from one of its ends to another end. Slat Chain Conveyor are used for goods which are heavy weights or sharp edges.



## INCLINED SLAT CONVEYOR



## MODULAR BELT CONVEYOR

Modular belt conveyors are extremely robust and can be used in a multitude of ways for almost every transport application. A modular belt consists of individual plastic modules usually linked together with joint rods. The conveyor system offers various chain materials to make it suitable for food, suitable for high temperatures or resistant to chemicals.

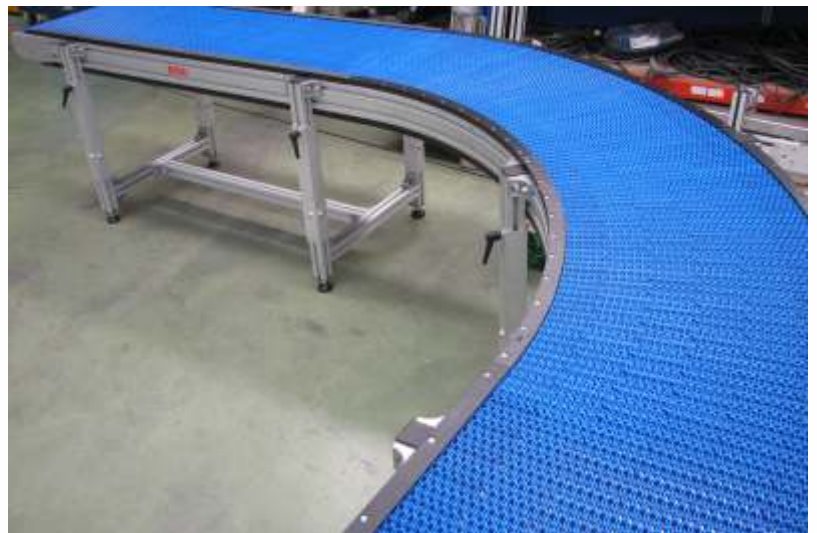

## WIRE MESH CONVEYOR:

Wire Mesh Belt Conveyors are the perfect choice for conveying hot, oily or dirty parts, and for drying or cooling products in virtually every industry. Wire Mesh Belt Conveyors are custom manufactured in a variety of shapes and sizes as per the application requirements.



## FLEXIBLE ROLLER CONVEYORS – (POWERED)

Known for proficient and reliable mechanism, flexible motorized roller conveyor can be installed easily. With its low cost maintenance, the product is expandable and adjustable to support various operations. We believe the enhanced durability and sustainability of our products make the roller conveyor resistant against different types of load, wears and impacts. The performance of sorting process within factory increases with the advanced features of flexible motorized roller conveyor. The verified range of our products is available in different varieties and at attractive price.



## FLEXIBLE ROLLER CONVEYORS – (GRAVITY )

Best Suitable in truck loading/unloading application. Requires less storage space when fully retracted. Available in both mild steel and stainless steel structure & Plastic.

**Less maintenance .**





## OVER HEAD CONVEYOR

This type of conveyor is used for material handling and paint shop. It is a continuous circuit of chain running through track and a variety of vertical and horizontal curves. There are two type of units.

- Drive unit that grabs the chain and pull it through the track.
- Take-up unit that ensures the chain is always stretched tight, even if it wears over many years of use.

### Various type of Controllers

Electrical controls can be simple on/off motor starter, a variable speed controller or it may have an industrial grade programmable logic controller or it may even have a PC or host system.

It depends on the customer demand.



## SKD LINE CONVEYOR

Semi Knocked Down An assembly line is an arrangement of workers and machines in a factory, where each worker deals with only one part of a product. The product passes from one worker to another until it is finished.



## TELESCOPIC CONVEYOR FOR TRUCK LOADING

Best Suitable in loading /Unloading Mobile conveyors (Truck Loading Conveyor) units for all applications ranging from Boxes, Cartons, Gunny Bags in warehouses, bottling plants, distilleries, etc and any places where material needs to be moved rapidly and efficiently.



**TELESCOPIC CONVEYOR FOR TRUCK LOADING**



## TOOL KIT BOX

We are manufacturing the Tool kit box for CNC & VMC Machines .



**CUSTOMIZED FABRICATION:**

Our Engineers interact with customers for their specific requirements and design the product as per their need. For complete design flexibility, choice of conveyor type with any reasonable length, discharge height and conveyor total heights can be selected from our wide range of conveyors.

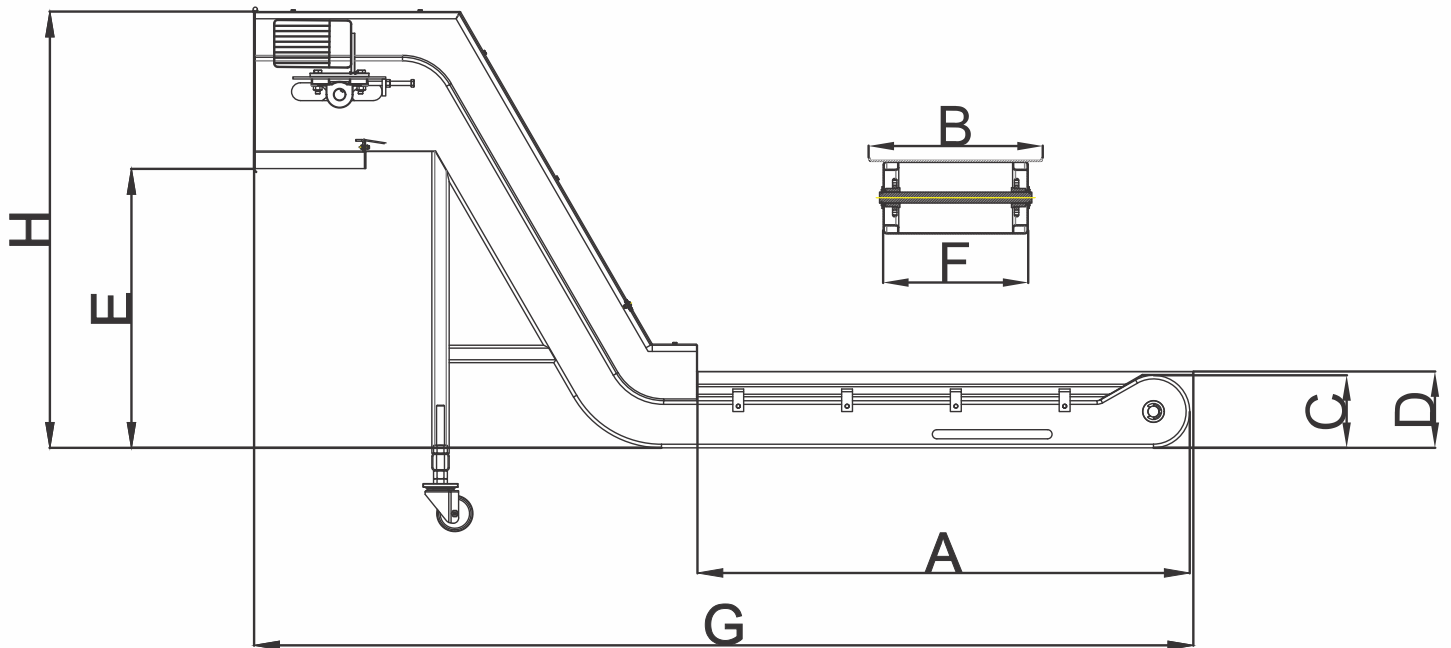

CODE	SPECIFICATION	DIMENSIONS (MM)
A	OPEN AREA/WORKING LENGTH	
B	TOTAL WIDTH	
C	CONVEYOR HEIGHT	
D	CONVEYOR TOTAL HEIGHT FROM GROUND LEVEL	
E	DISCHARGE HEIGHT	
F	CHAIN WIDTH	
G	TOTAL LENGTH	
H	CONVEYOR TOTAL HEIGHT	



Industrial Area-C, Dhandari Kalan, Ludhiana-141010 (INDIA)  
Phone : +91161 5244020  
Fax : +91 161 2511600 Mob : +91 98145 15141  
Email : [yateesh@eastmanconveyors.com](mailto:yateesh@eastmanconveyors.com)  
Web : [www.eastmanconveyors.com](http://www.eastmanconveyors.com)